

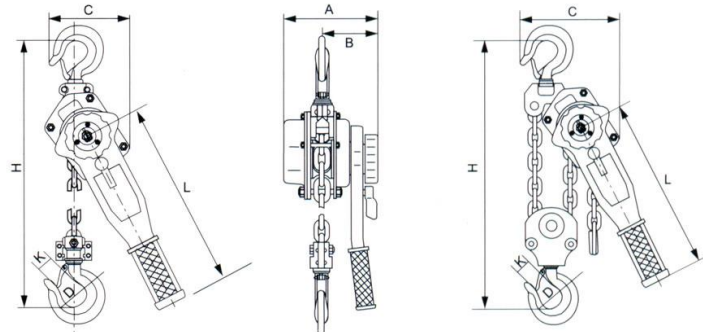

POLIPASTOS
DE MÉXICO S.A. DE C.V.

LH-A TYPE LEVER HOIST

- H-lift lever hoist is a universal, manual hoist for lifting, tensioning and lashing in any direction.
- The ratchet lever hoist features compact design and robust, deep drawn, stamped steel construction.
- High quality materials ensure light weight without infringing reliability.
- Low own weight, small mounting sizes and small lever force at full load.
- Asbestos free brake, holding load at any desired height.
- Top & Bottom hooks are fitted with safety latches as standard.
- The load chain can be pulled freely and easily through the hoist in both directions to attach the load or to tension the chain. For safety reason, free chains can not be done when the hoist is under load.
- Short hand lever with rubber grip.
- Hand lever operates with little effort due to optimal gear ratio.
- Drop forged steel suspension & load hooks are heat treated and fracture resistant. In case of dangerous overloading or abuse, the hook does not fracture but will slowly yield.
- The hoist is fitted with high grade alloy load chain.
- Complies with EC Council Directive 98/37/EC Machinery, ASME B30, AS1418.2.
- Overload protection device available upon request.
- Sealed bearing available upon request.



0.75t, 1.5t, 3t

6t

Model		LHA075	LHA150	LHA300	LHA600	LHA900
Capacity	t	0.75	1.5	3	6	9
Standard Lift	m	1.5	1.5	1.5	1.5	1.5
Proof Load	kN	11.0	22.1	44.1	88.2	132.3
Effort Required to Lift Rated Load	N	140	220	320	340	360
No. of Falls of Load Chain		1	1	1	2	3
Load Chain	mm	6 x 18	8 x 24	10 x 30	10 x 30	10 x 30
Dimensions (mm)	A	145	175	203	203	203
	B	86	100	118	118	118
	C	122	130	150	205	316
	D	37	45	50	64	85
	H	320	380	480	620	700
	L	280	410	410	410	410
	K	30	36	40	50	64
Net Weight	kg	7.5	11.5	21	31.5	47
Extra Weight per Metre of Extra Lift	kg	0.8	1.4	2.2	4.4	6.6