

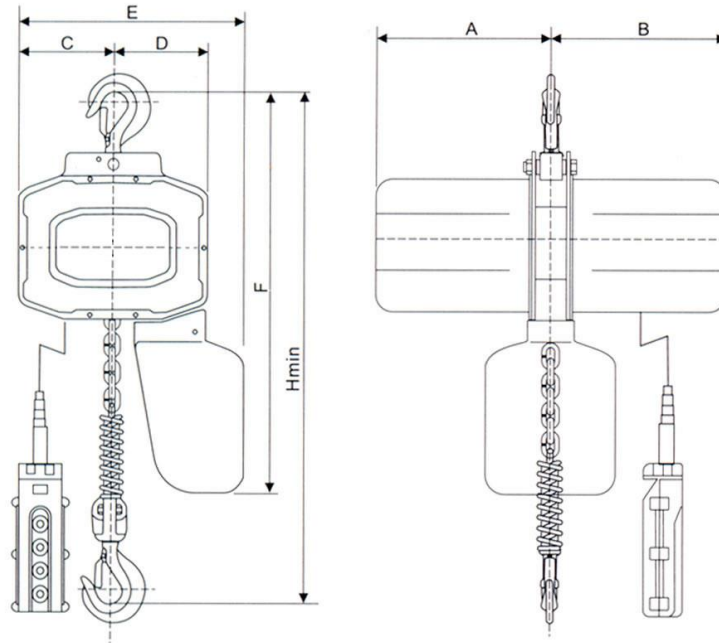

POLIPASTOS
DE MÉXICO S.A. DE C.V.



- With suspension hook, push, geared or electric trolley.
- Standard lift height 3m, control cable 2.5m, operating voltage 220-500V, 50/60Hz, 1-3 phase.
- Low voltage control 24V is standard. 36V, 48V is optional.
- High efficient energy-saving motor, asbestos free brake system.
- Light weight, compact and solid body case.
- Top and bottom hooks are fitted with safety latches as standard.
- Drop forged steel suspension & load hooks are heat treated and fracture resistant. In case of dangerous overloading or abuse, the hook does not fracture but will slowly yield.
- Strong chain bucket.
- Super strong surface hardened chain.
- Limit switch devices fitted at both top & bottom ends, switch off power automatically to prevent load chain from running out.
- Over load protection and thermal protection.

| Model | | EHC-005 | EHC-010 | EHC-020 | EHC-030 | EHC-030D | EHC-050 |
|--------------------------------------|-------|----------------------------------|-----------|-----------|-----------|----------|----------|
| Capacity | ton | 0.5 | 1.0 | 2.0 | 3.0 | 3.0 | 5.0 |
| Standard Lift | m | 3 | 3 | 3 | 3 | 3 | 3 |
| Lifting Speed | m/min | 7/2.33 | 7/2.33 | 3.5/1.17 | 2.3/0.76 | 4/1.33 | 2.6/0.86 |
| Motor Power | kw | 0.8/0.27 | 1.6/0.53 | 1.6/0.53 | 1.6/0.53 | 3.0/1.0 | 3.0/1.0 |
| Power Supply | | 1-3 Phase, 50/60HZ, 220/380/440V | | | | | |
| Duty Rating | | 40% | | | | | |
| Load Chain | | 7.1x21(1) | 7.1x21(1) | 7.1x21(2) | 7.1x21(3) | 9x27(2) | 9x27(3) |
| Proof Load | kN | 6.25 | 12.5 | 25 | 37.5 | 37.5 | 62.5 |
| Cable Length | m | 2.5 | 2.5 | 2.5 | 2.5 | 2.5 | 2.5 |
| Extra Weight per Meter of Extra Lift | kg | 1.1 | 1.1 | 2.2 | 3.3 | 3.5 | 5.3 |
| H min | mm | 500 | 520 | 630 | 710 | 800 | 850 |
| Dimensions (mm) | A | 245 | 245 | 245 | 245 | 265 | 265 |
| | B | 245 | 245 | 245 | 245 | 265 | 265 |
| | C | 158 | 158 | 124 | 124 | 127 | 127 |
| | D | 142 | 142 | 176 | 176 | 205 | 205 |
| | E | 350 | 350 | 350 | 350 | 393 | 393 |
| | F | 600 | 600 | 610 | 620 | 738 | 738 |
| Net Weight | kg | 50 | 55 | 60 | 65 | 78 | 85 |